

Installation • Operation Manual

Condensate Neutralizer Kit

Item Number ECHNK01

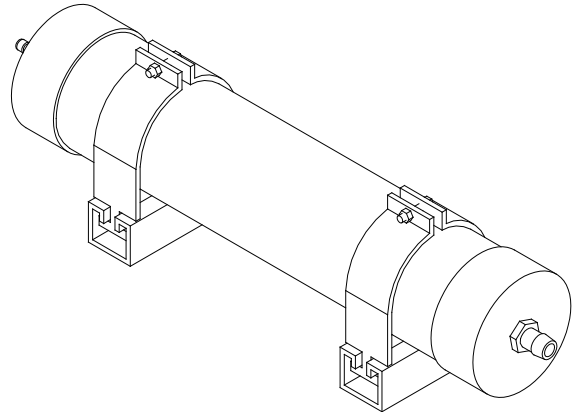

Service Information Center:

Call us first if you have any questions with this product. We can help you with questions about assembly and operation or if there are any damaged or missing parts when you unpack this part from the shipping box. Please call before returning.

1-866-946-1096

7am-7pm CST, Monday through Friday

IMPORTANT:

- **Only specially trained and authorized personnel are permitted to service this product.**
- **NOTE TO ASSEMBLER/INSTALLER:**
Leave this manual with the consumer.
- **NOTE TO CONSUMER:**
Keep this manual for future reference.



WARNING



Turn off the electrical supply, the manual gas control valve, and the manual water control valve before installing or servicing.

Overview

Overview

What is pH?

The pH measurement of a fluid is an indicator of the acidity or alkalinity. Neutral fluids have a pH of 7.0. Acid fluids have a pH below 7 and alkaline fluids have a pH above 7 (up to 14). The pH can be easily measured using litmus paper.

Condensate from the Eternal Water Heater is typically around 4 (slightly acidic). The condensate needs to be increased (made more neutral) to prevent possible damage to cast iron soil pipe, ABS pipe, septic tanks, plants, wastewater treatment plants and other materials handling waste water.

The Eternal Condensate Neutralizer Kit increases pH (reduces acidity)

The Eternal Condensate Neutralizer Kit is designed to raise the pH level of the condensate discharged by the Eternal Water Heater.

Each change of 1.0 in pH is a 10-times reduction or (increase) in concentration. The pH of condensate is increased by approximately 1.0 to 3.0 higher after passing through the Condensate Neutralizer Kit. (This is a change in concentration from 10 to 30 times.)

Applying the Eternal Condensate Neutralizer Kit

Condensate can be collected from flueways and water heater condensate trap outlets. Use a separate neutralizing kit for each connection. **DO NOT combine condensate lines from flueways with those from water heater condensate traps.** Match Neutralizer Kit to ratings on water heater. Locate the Eternal Neutralizer Kit below the condensate connection and slightly above the floor drain or inlet to a condensate pump reservoir (if used).

Follow the guidelines in this manual, the directions in the Eternal Water Heater Operation Manual, and all applicable local, state, and federal codes when installing, using, and maintaining the Eternal Condensate Neutralizer Kit.



CAUTION



Before Commencing The Installation

Check that it is in accordance with relevant building and mechanical codes, as well as any local or state or federal regulations.

Parts List and Diagram

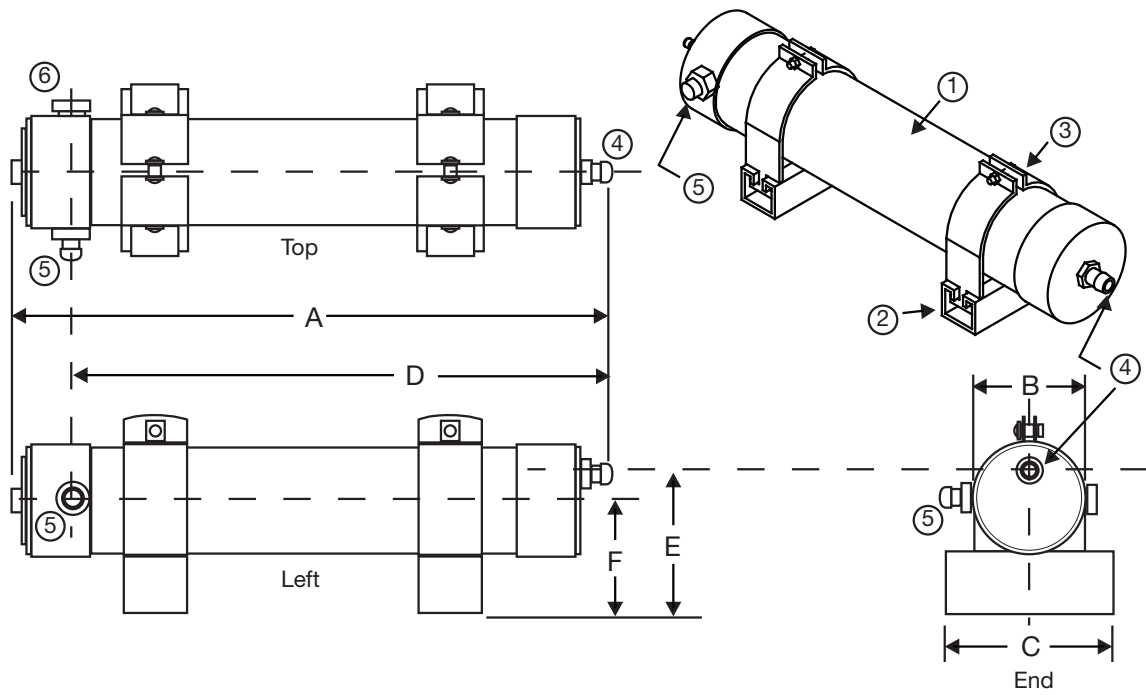

Key	Description
1	PVC Tubing filled with 1/2" and 3/4" Aggregate Calcium Carbonate
2	Channel Strut Mounts
3	Galvanized Strut Clamps, Bolts, and Nuts
4	Condensate Outlet Hose Barb Fitting
5	Condensate Inlet Hose Barb Fitting
6	Plugged-Alternate Location for Condensate Inlet Hose Barb Fitting

Note: Hose Barb Fittings to 30'. 3/4" Hose Barb to 1/2" NPT

Ratings and Dimensions (in inches)							
MPH	GPH	A	B	C	D	E	F
200	2	15	2 3/4"	3 7/8"	N/A	2 1/4"	2 1/4"

Installation and Maintenance

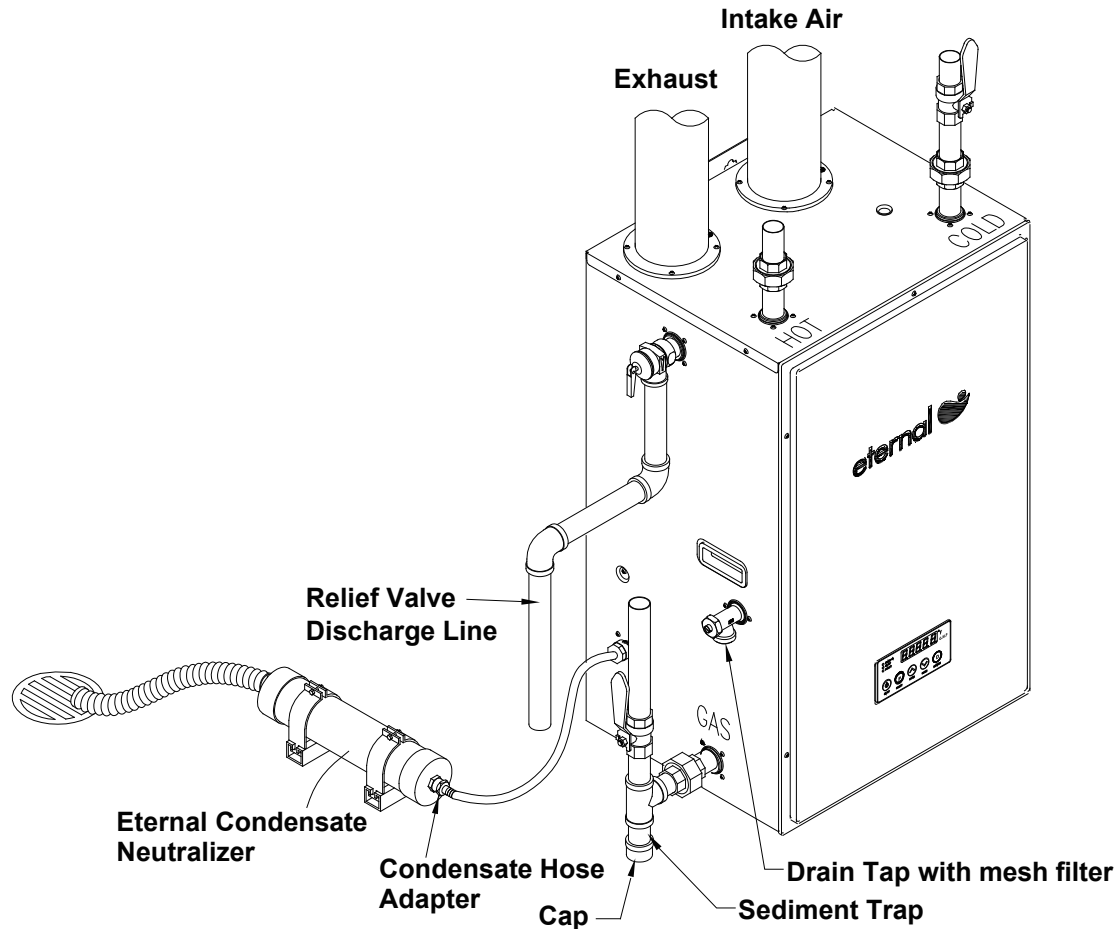

(These diagrams are for reference as basic guides. Each installation should be engineered properly and compliant to Local, State, and Federal Codes.)

Installation Instructions:

1. Securely fasten the two bases to floor or wall.
2. Mount tubes across bases and secure with the two clamps.
3. Connect plastic tubes or PVC piping from appliance or breeching drains to P-traps and then from P-trap outlet to either one of the two Kit inlets.
4. Connect the Kit outlet to house drain or condensate pump.
5. Use Teflon tape on all threaded plastic fittings.
6. NOTE- Always contact the local authority in regards to any requirements concerning flue gas condensate handling codes.

Installation Notes:

- Bottom of water heater condensate outlet **MUST** be ABOVE bottom of Neutralizer Kit outlet
- Neutralizer Kit must be installed lower than condensate outlet in a horizontal position to prevent backflow
- Condensate outlet must be oriented up with the condensate inlet into the side
- When using PVC pipe, remove the inlet and outlet hose barb fittings and replace with threaded PVC fittings. Include unions in the piping to allow removal of the tube for inspection and service.
- When securing pipe or tubing in place, protect with a shield if necessary if routed through traffic areas.
- Use hose clamps at all connections when using plastic tubing.
- If the condensate drain termination is located at the floor drain or the condensate pump reservoir inlet, make sure it is secured in place with clamps.
- Elevate the Kit on a structural base if necessary for the outlet to be raised.
- Route discharge line from condensate pump assembly per instructions supplied by pump manufacturer.

Installation and Maintenance



WARNING



- Apply to flue gas condensing water heater and breeching condensate drains only.
- **DO NOT** exhaust flue gases through the Neutralizer Kit. It is not rated for water heater flue gases.
Operating the Neutralizer Kit as an exhaust vent can cause injury or death from carbon monoxide.
- **DO NOT** combine vent condensate drain lines and water heater condensate lines. Use a separate Neutralizer Kit for each application.
- Neutralizer Kit must be installed below system P-traps, water heater and breeching condensate drains.
- Gas traps must be installed between the water heater, vent drains, and water condensate outlet and the inlet of Neutralizer Kit.
- Before operating the water heater, fill the Neutralizer Kit and traps with tap water.
- **NEVER** operate with Kit or P-Traps dry.
- Kit should be recharged yearly (every 2,000 operating hours) or when pH level moves below 6.
- **Failure to comply with these guidelines could result in severe personal injury, death, or property damage.**

Maintenance Instructions:

Installer: Instruct the building owner to frequently inspect the Neutralizer Kit and all condensate connections. The owner must notify a qualified technician if any problems are noticed.

Instruct the building owner to schedule an annual (or every 2,000 operating hours) recharge of the Neutralizer Kit. Contact Grand Hall for replacement parts.